

Refractometer

Instructions for Use

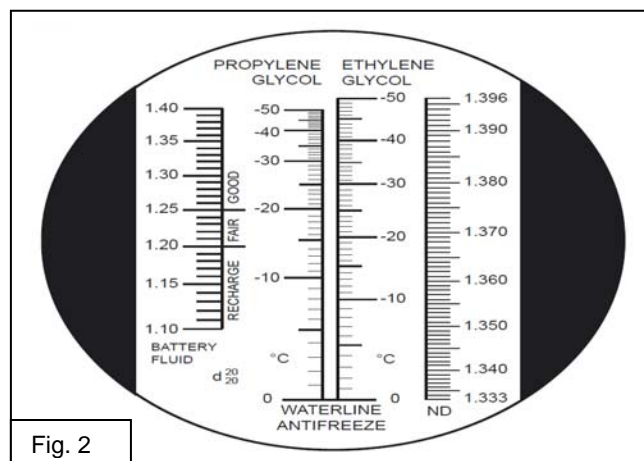

Freezing point measurement of TYFOCOR® L / water mixtures and TYFOCOR® LS ready-to-use

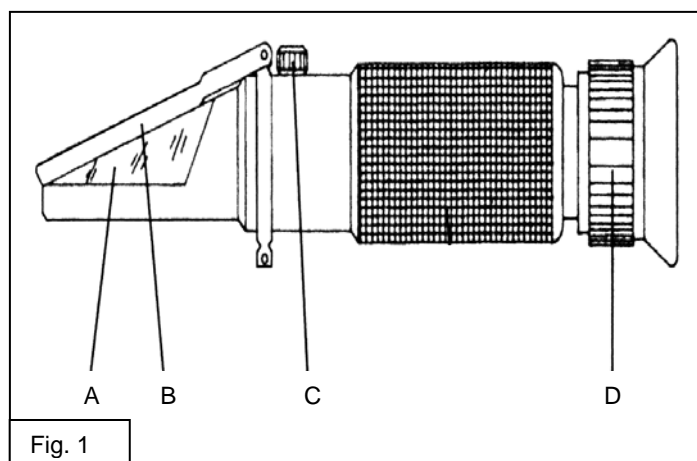

General

The refractometer (Fig. 1) allows rapid and accurate check of freezing points of coolants and heat-transfer media based on ethylene glycol and propylene glycol by reading from the respective scales (Fig. 2). The refractive index (ND) of the sample fluid is simultaneously displayed. Battery acid can also be checked with the aid of this measuring device.

Calibration procedure

1. Open the illuminating plate (B), apply 1-2 drops of distilled water onto the prism surface (A) by using the pipette contained in the test set and press the plate onto the prism surface.
2. Turn the pointy end of the refractometer to the light and look into the eyepiece (D). Focus the scale to your vision by rotating the eyepiece until the scale is clear and easy to read. Rotate the adjusting screw (C) with the screwdriver included in the test set so that the light / dark boundary line evens up with the zero line (Fig. 2, WATERLINE). After the calibration procedure, dry the surfaces properly.

Measurement procedure

1. Open the illuminating plate, apply 1-2 drops of test fluid onto the prism surface, close illuminating plate.

2. Turn the pointy end of the refractometer to the light, rotate the eyepiece until the light / dark boundary line becomes visible. The line indicates the **frost protection** of TYFOCOR® L / water mixtures and of TYFOCOR® LS ready-to-use (reading from the propylene glycol scale). The antifreeze effect of TYFOCOR® L and TYFOCOR® LS ready-to-use is further explained on page 2.

Instructions for measuring

1. Place a few drops of a sample liquid on prism surface, make sure that it is entirely covered. The light / dark boundary line cannot be seen clearly if too much or too little sample liquid is present. After measuring, the sample liquid must be removed from the prism surface by carefully rinsing it with water and drying with a clean cloth. Incorrect reading can result from a poorly cleaned and dried prism surface.
2. If the refractometer is contaminated by oil, grease or similar matter, an accurate measurement is not possible, since the fluid will be repelled from the prism surface. In this case clean the surface with a spiritus soaked cloth and dry it properly afterwards.
3. Do not damage the prism surface. Do not clean the refractometer under running water. It is splash-proof, but not waterproof.



TYFOROP Chemie GmbH

Anton-Rée-Weg 7 D-20537 Hamburg Tel./Fax: +49 (0)40 20 94 97-0/20 e-mail: info@tyfo.de

02/13, p.1

Refractometer

Instructions for Use



Freezing point measurement of TYFOCOR[®] L / water mixtures and TYFOCOR[®] LS ready-to-use

Antifreeze effect of TYFOCOR[®] L / water mixtures and TYFOCOR[®] LS ready-to-use

TYFOCOR[®] L (based on propylene glycol) lowers the freezing point of water down to -50 °C, depending on the concentration. TYFOCOR[®] LS ready-to-use bases on a fixed ratio of propylene glycol and deionized water, and thus provides **frost protection** of -28 °C.

The **freezing point**, colloquially called “antifreeze”, is a measure for the freezing-point depression of antifreeze fluids. When a given TYFOCOR[®] L / water mixture or TYFOCOR[®] LS ready-to-use will be cooled down, the freezing point is the temperature at which initial ice crystals begin to form. The resulting ice slurry does not possess any expansive force. Further reduction in temperature causes further thickening of the ice slurry until it solidifies at the **pour point**. Only below this temperature, there is danger of bursting for the installation. The arithmetic mean from freezing point and pour point is referred to as **frost protection**.

The following table displays the freezing points, frost protection and pour points of TYFOCOR[®] L / water mixtures and TYFOCOR[®] LS ready-to-use as a function of the concentration. Regarding TYFOCOR[®] LS ready-to-use it is important to note that the fluid, which has been developed for use in vacuum tube collectors, must not be diluted with water. The values given are for information purposes only, e.g. in case of unintended dilution caused by remainders of flushing water after the system has been installed.

TYFOCOR[®] L

(reading from propylene glycol scale)

TYFOCOR[®] LS ready-to-use, frost protection -28 °C

(reading from propylene glycol scale)

% vol.	Freezing point	Frost protection Reading	Pour point	% vol.	Freezing point	Frost protection Reading	Pour point
25	- 10.7 °C	- 11.5 °C	- 12.3 °C	100	- 25 °C	- 28 °C	- 31 °C
30	- 14.0 °C	- 15.0 °C	- 16.0 °C	Inadmissible Dilution			
35	- 17.6 °C	- 19.0 °C	- 20.4 °C	95	- 23 °C	- 25 °C	- 27 °C
40	- 21.5 °C	- 23.7 °C	- 26.0 °C	90	- 21 °C	- 23 °C	- 25 °C
45	- 26.0 °C	- 29.6 °C	- 33.3 °C	85	- 18 °C	- 20 °C	- 22 °C
50	- 32.4 °C	- 38.2 °C	- 44.0 °C	80	- 16 °C	- 18 °C	- 20 °C
55	-40.4 °C	-48.5 °C	< -50 °C	75	- 14 °C	- 16 °C	- 18 °C
55	- 48.4 °C	< -50 °C	< - 50 °C	70	- 12 °C	- 14 °C	- 16 °C

In order to maintain effective protection from frost and corrosion, a concentration of at least 40 volume percent of TYFOCOR[®] L Concentrate must be applied for use in Solar Thermal Systems.

TYFOCOR[®] LS ready-to-use must not be diluted with water, and must never be mixed with other heat-transfer fluids.



TYFOROP Chemie GmbH

Anton-Rée-Weg 7 D-20537 Hamburg Tel./Fax: +49 (0)40 20 94 97-0/20 e-mail: info@tyfo.de 02/13, p.2